



PROJECTOR LIFT SI-H 100

The projector lift **SI-H 100** is studied in order to support large and heavy video projectors up to 25 Kg. of weight. The lift has been developed to be installed inside a false ceiling in order to hide the projector, lift and cables, thus granting the best aesthetic and practical solution. The **SI-H 100** is supplied with an extremely silent motor that allows a descent from a minimum of 14,5 cm. to a maximum of 96 cm.

Moreover it is supplied with extendable side brackets in order to allow an easy fixing of the panel of your false ceiling by adjustable threaded bars. The panel can be mounted under the projector, even if the projector is larger as the lift itself.



PROJECTOR LIFT
PARTLY OPEN



PROJECTOR LIFT
CLOSED



PROJECTOR LIFT
SIDE VIEW

The lift SI-H 100 is equipped with two **SAFETY SCREWS** that prevent the lift to extent further to the preset end stop.

One more interesting element of this lift is a **CABLES GATHERING SYSTEM** with a raceway where to put the cables of the projector, so they will be hidden and tidy gathered together when the projector lift is going up.

TECHNICAL SPECIFICATIONS

- POWER SUPPLY
- MAXIMUM CONSUMPTION
- TORQUE
- MOTOR SPEED
- MINIMUM DIMENSIONS LIFT CLOSED
- DIMENSIONS LIFT OPENED
- MAXIMUM SIZE FIXING POINTS PROJECTOR
- MAXIMUM LOAD
- MAXIMUM OVERALL SIZE OF PROJECTOR
- NET WEIGHT OF THE PROJECTOR LIFT
- CABLE GATHERING SYSTEM

220-230 V 50 HZ

184 W

20 Nm

17 Rpm

576x145x555 mm. (WxHxD)

576x960x555 mm. (WxHxD)

370x400 mm. (WxD)

25 KG.

570x600 mm. (WxD)

12 KG.

20x18 mm. (WxH)

Warranty
24 months

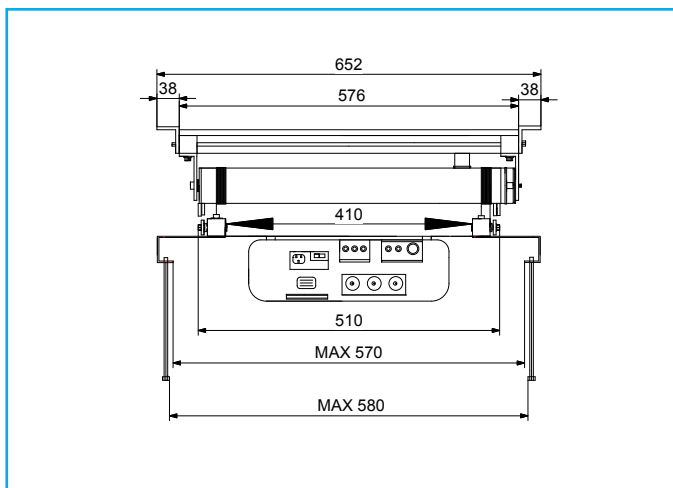

CLOSED LIFT: FRONTAL VIEW

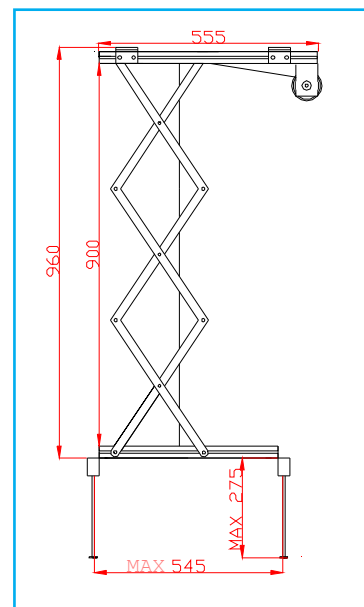

OPEN LIFT: SIDE VIEW

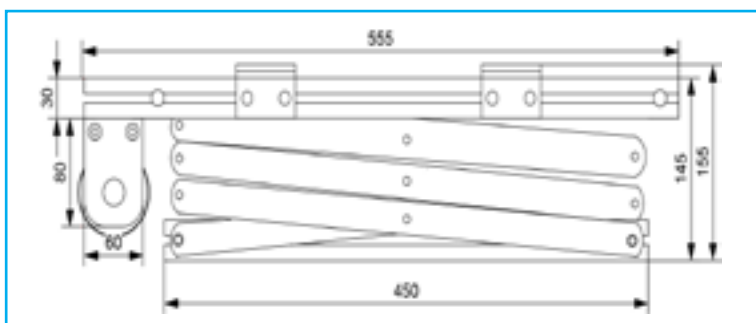

CLOSED LIFT: SIDE VIEW

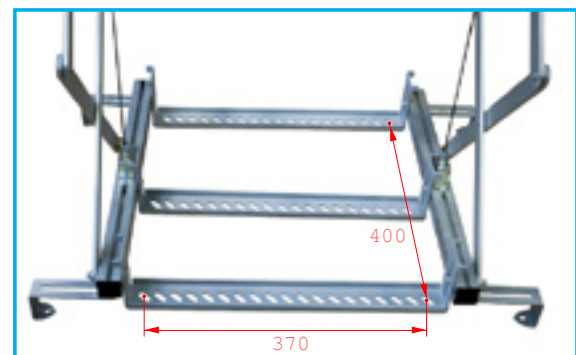

**MAXIMUM SIZE FIXING
POINTS PROJECTOR**

* The measures of the drawings are expressed in millimetres.

Euroscreen S.r.l.
Via Stiria, 45/16 - 33100 Udine - Italy
Tel. +39 0432 522755
Fax +39 0432 524000
www.screenint.com
info@screenint.com

